

# Extrakranielle non-coplanare Radiotherapie

## Optimierung in der Praxis durch **MapRT**

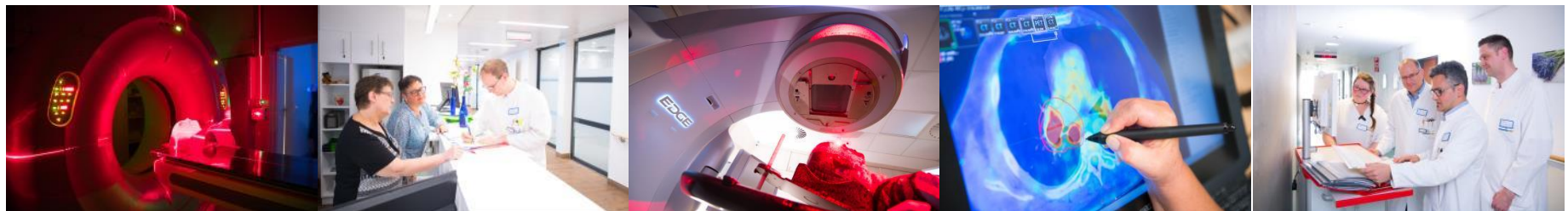

Gemeinsam fürs Leben

# Discosure

Die Klinikum Darmstadt GmbH, hat ein “**professional service agreement**” / Referenzkundenverträge mit Varian (Siemens Healthineers International AG) und Vision RT.

Christian Weiß erhält/erhielt Honorare und Unterstützung durch Varian Medical Systems, Vision RT, Merck Serono, Roche, MSD, BMS, Eli Lilly, Sanofi Aventis, Janssen Cilag

# Von 2D zu 3D IMRT – VMAT und 4D .....

ab ~ 2005

Radiochirurgie mit CyberKnife, Tomotherapie,  
Partikeltherapie mit Protonen und Ionen

**Adaptive  
RT**

**VMAT**

**IMRT**

ab ~2010

4D-Bestrahlungsplanung,  
Bestrahlung bewegter  
Zielvolumina mit Gating-und  
Tracking-Techniken ,  
dynamische Rotations-IMRT  
(„VMAT = volume-modulated  
arc therapy“, z.B. RapidArc).  
Autosegmentierung

**3D**

ab 2000  
Einführung der  
IMRT  
(intensitätsmodulierte  
Radiotherapie)

Ab 1990  
3-D  
konformaleRT

**2D**

Linac´s  
ab Ende 70er

# Non-coplanare Bestrahlung am LINAC

Technique	Clinical sites investigated	Technological approach	Computational methods	Clinical implementation	Challenges
NC-IMRT	Liver <sup>13,19,22</sup> lung <sup>14</sup> brain <sup>15,20,21</sup> head & neck <sup>16</sup> prostate <sup>17,18</sup>	Up to 30 static non-coplanar beams	Beam orientation optimization using existing methods <sup>13-22</sup>	Ready for implementation	Automated trajectory sequencing
SCNC-VMAT	Brain <sup>23-27</sup>	VMAT with multiple fixed patient couch rotations	Manual selection from limited arc set	Ready for implementation	Automated delivery and collision prevention on non-HyperArc platforms
Coronal VMAT	Partial breast <sup>28-31</sup>	Dynamic patient couch rotation with fixed or limited linac gantry rotation	Manual <sup>28,29</sup> or algorithmic <sup>30,31</sup> trajectory definition	Requires substantial further development	Collision prevention Intrafraction motion Patient compliance Investigation of other clinical sites Non-research delivery technology
Trajectory VMAT	Brain <sup>33,35-42,44</sup> head & neck <sup>32,34,43</sup> prostate <sup>38,40,44</sup> lung <sup>40-42,44</sup> liver <sup>42</sup> chest wall <sup>44</sup> oesophagus <sup>44</sup>	Synchronized dynamic patient couch rotation and linac gantry rotation.	Manual <sup>33,34</sup> or mathematical <sup>37</sup> trajectory definition Beam scoring <sup>35,36,38,39</sup> or fluence-based <sup>32,39-42,44</sup> trajectory optimization	Requires substantial further development	Collision prevention Intrafraction motion Patient compliance Non-research delivery technology
CyberArc	Brain and prostate <sup>45,46</sup>	Arc delivery sequencing for robotic arm mounted linac	Dose mimicking and fluence-based trajectory optimization <sup>45,46</sup>	Requires some further development	Integration into proprietary treatment planning and linac control software
Dynamic Wave Arc	Brain <sup>48</sup> metastatic disease <sup>47,49</sup> prostate <sup>47,49</sup> pancreas <sup>47</sup> lung <sup>47,49</sup> breast <sup>49</sup>	Dynamic rotation of O-ring linac	Manual definition <sup>47-50</sup>	Ready for implementation	Application of trajectory optimization techniques to O-ring linac geometry

Smyth G et al. Br J Radiol 2019

# Non-coplanare Bestrahlung am LINAC

Technique	Clinical sites investigated	Technological approach	Computational methods	Clinical implementation	Challenges
NC-IMRT	Liver <sup>13,19,22</sup> lung <sup>14</sup> brain <sup>15,20,21</sup> head & neck <sup>16</sup> prostate <sup>17,18</sup>	Up to 30 static non-coplanar beams	Beam orientation optimization using existing methods <sup>13-22</sup>	Ready for implementation	Automated trajectory sequencing
SCNC-VMAT	Brain <sup>23-27</sup>	VMAT with multiple fixed patient couch rotations	Manual selection from limited arc set	Ready for implementation	Automated delivery and collision prevention on non-HyperArc platforms
Coronal VMAT	Partial breast <sup>28-31</sup>	Dynamic patient couch rotation with fixed or limited linac gantry rotation	Manual <sup>28,29</sup> or algorithmic <sup>30,31</sup> trajectory definition	Requires substantial further development	Collision prevention Intrafraction motion Patient compliance Investigation of other clinical sites Non-research delivery technology
Trajectory VMAT	Brain <sup>33,35-42,44</sup> head & neck <sup>32,34,43</sup> prostate <sup>38,40,44</sup> lung <sup>40-42,44</sup> liver <sup>42</sup> chest wall <sup>44</sup> oesophagus <sup>44</sup>	Synchronized dynamic patient couch rotation and linac gantry rotation.	Manual <sup>33,34</sup> or mathematical <sup>37</sup> trajectory definition Beam scoring <sup>35,36,38,39</sup> or fluence-based <sup>32,39-42,44</sup> trajectory optimization	Requires substantial further development	Collision prevention Intrafraction motion Patient compliance Non-research delivery technology
CyberArc	Brain and prostate <sup>45,46</sup>	Arc delivery sequencing for robotic arm mounted linac	Dose mimicking and fluence-based trajectory optimization <sup>45,46</sup>	Requires some further development	Integration into proprietary treatment planning and linac control software
Dynamic Wave Arc	Brain <sup>48</sup> metastatic disease <sup>47,49</sup> prostate <sup>47,49</sup> pancreas <sup>47</sup> lung <sup>47,49</sup> breast <sup>49</sup>	Dynamic rotation of O-ring linac	Manual definition <sup>47-50</sup>	Ready for implementation	Application of trajectory optimization techniques to O-ring linac geometry

Smyth G et al. Br J Radiol 2019

# Kranielle non-coplanare Bestrahlung

## CEREBRAL RADIATION SURGERY USING MOVING FIELD IRRADIATION AT A LINEAR ACCELERATOR FACILITY

GÜNTHER H. HARTMANN, PH.D.,<sup>1</sup> WOLFGANG SCHLEGEL, PH.D.,<sup>1</sup> VOLKER STURM, M.D.,<sup>2</sup>  
BERND KOBER, M.D.,<sup>3</sup> OTTO PASTYR, ENG.<sup>1</sup> AND WALTER J. LORENZ, PH.D.<sup>1</sup>

Institut für Nuklearmedizin, Deutsches Krebsforschungszentrum; <sup>2</sup>Neurochirurgische Abteilung der Universität und Tumorzentrum Heidelberg Mannheim; and <sup>3</sup>Universitätsstrahlenklinik Heidelberg, D-6900 Heidelberg 1, PO Box 101949, Federal Republic of Germany

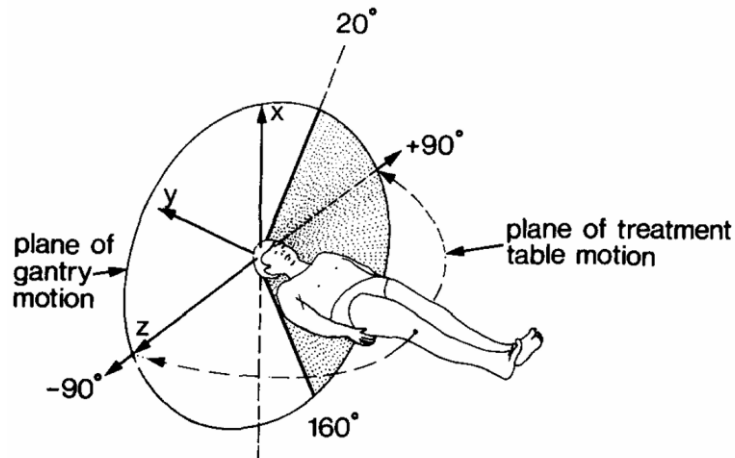
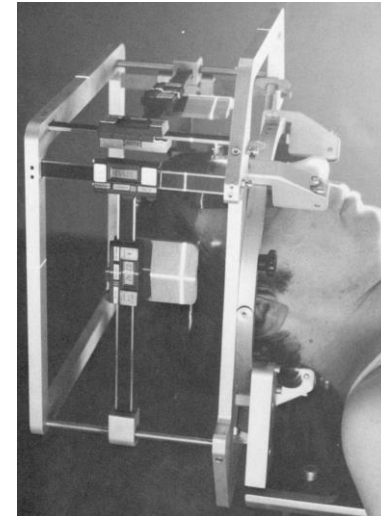

Fig. 1. Schematic illustration of the three dimensional cross fire irradiation. The shadowed area represents the moving field angle ( $20^{\circ}$ – $160^{\circ}$ ). Each of the 11 irradiations is performed at a different angle of the treatment table varying between  $-90^{\circ}$  and  $+90^{\circ}$ .



# Kranielle non-coplanare Bestrahlung

## CEREBRAL RADIATION SURGERY USING MOVING FIELD IRRADIATION AT A LINEAR ACCELERATOR FACILITY

GÜNTHER H. HARTMANN, PH.D.,<sup>1</sup> WOLFGANG SCHLEGEL, PH.D.,<sup>1</sup> VOLKER STURM, M.D.,<sup>2</sup>  
BERND KOBER, M.D.,<sup>3</sup> OTTO PASTYR, ENG.<sup>1</sup> AND WALTER J. LORENZ, PH.D.<sup>1</sup>

Institut für Nuklearmedizin, Deutsches Krebsforschungszentrum; <sup>2</sup>Neurochirurgische Abteilung der Universität und  
Tumorzentrum Heidelberg Mannheim; and <sup>3</sup>Universitätsstrahlenklinik Heidelberg,  
D-6900 Heidelberg 1, PO Box 101949, Federal Republic of Germany

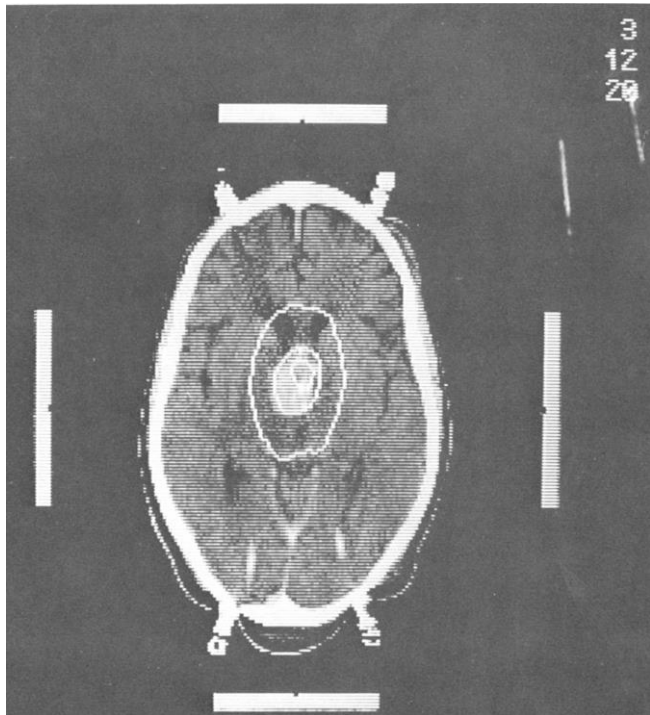

Hartmann GH IJROBP 1985

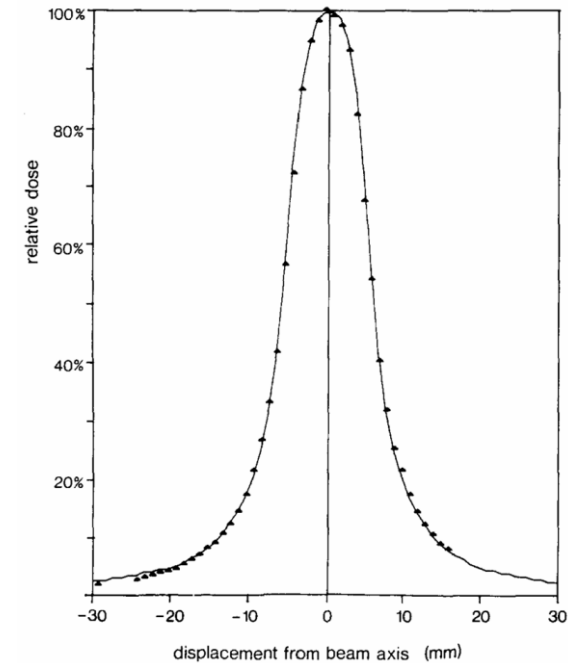
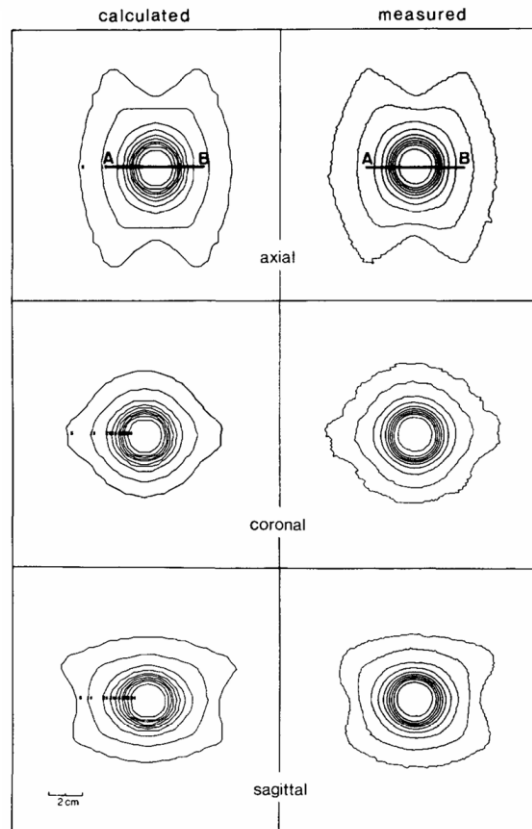

# Kranielle non-coplanare Radiotherapie (HyperArc™)

Erster Praktischer Einsatz: Juni 2018

Planungsbeispiel: EDGE, 6FFF

HyperArc  
SRS NTO

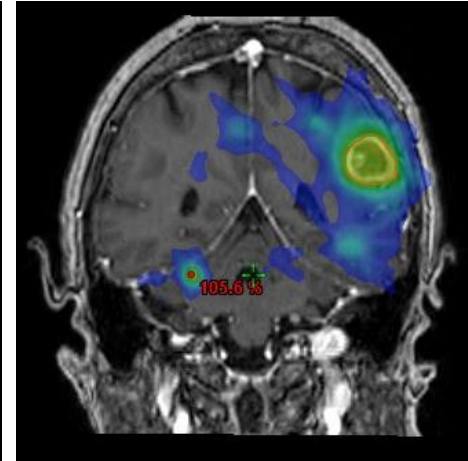
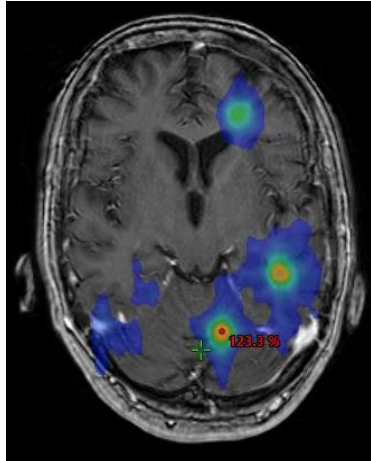
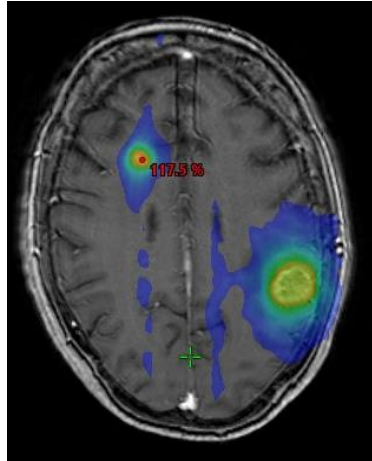

NTO

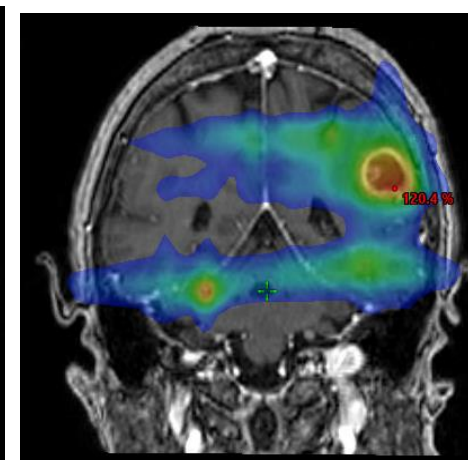
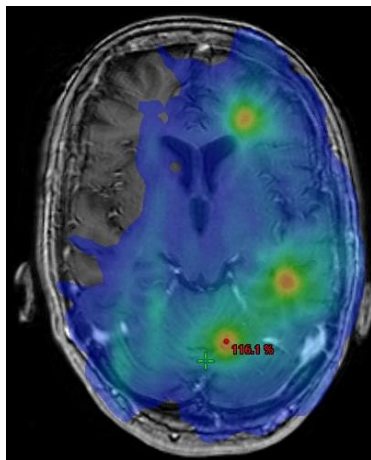
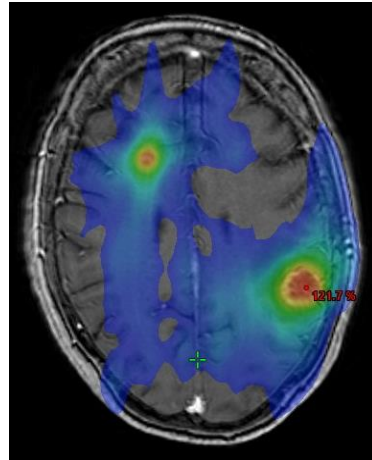



# Extrakranielle non-coplanare Bestrahlung – Muss oder Spielerei –

Extrakranielle non-coplanare Bestrahlung

Nutzung in der Routine

in Ausnahmefällen vorstellbar

eher Spielerei

# Extrakranielle non-coplanare Bestrahlung – Muss oder Spielerei –



**Con´s**

- **Komplexe Planung**
- **Höheres Risiko für Einstellungsfehler**
- **Erhöhtes Kollisionsrisiko**
- **Behandlungszeit**
- **Nur geringe Planverbesserung**



**Pro´s**



**Realität?  
Praxis?**

# Extrakranielle non-coplanare Bestrahlung – Muss oder Spielerei –

**Con´s**

- Komplexe Planung
- Höheres Risiko für Einstellungsfehler
- Erhöhtes Kollisionsrisiko
- Längere Behandlungszeit
- nur geringe Planverbesserung

**Pro´s**

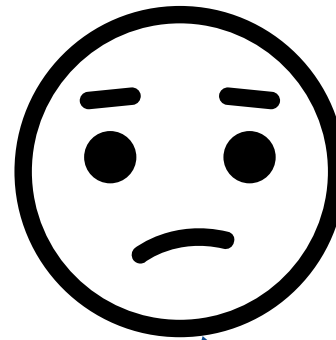

**Vielen Dank für ihre  
Aufmerksamkeit!**

**Realität?  
Praxis?**

# Extrakranielle non-coplanare Bestrahlung – Muss oder Spielerei –

## Con's

- Komplexe Planung
- Höheres Risiko für Einstellungsfehler
- Erhöhtes Kollisionsrisiko
- Behandlungszeit
- Nur geringe Planverbesserung

## Pro's

- **steilerer Dosisabfall**
- **bessere Konformität**
- **bessere Schonung OAR's**
- **weniger Nebenwirkungen**
- **Dosiseskalation**
- **bessere lokale Kontrolle**

Realität?  
Praxis?

# Extrakranielle non-coplanare Bestrahlung – Muss oder Spielerei –

Con's

Pro's

Besondere Bedeutung bei stereotaktischen  
Hochpräzisionstherapien, extremer  
Hypofraktionierung, Schonung von OAR'S,  
Dosisescalation

Praxis?

- - 
  - 
  - E
  - Ko
  - Be
  - Nu
  - Plan
- ...ungen  
• ...skalation  
• ...essere lokale  
• Kontrolle

# Klinisches Szenario 1: Leber SBRT

4pi Non-Coplanar Liver SBRT: A Novel Delivery Technique

n=10, Dosis 50-60Gy in 5#, VMAT-SBRT

**14-22** non-coplanare Felder vs VMAT-Plan – Behandlungszeit ???

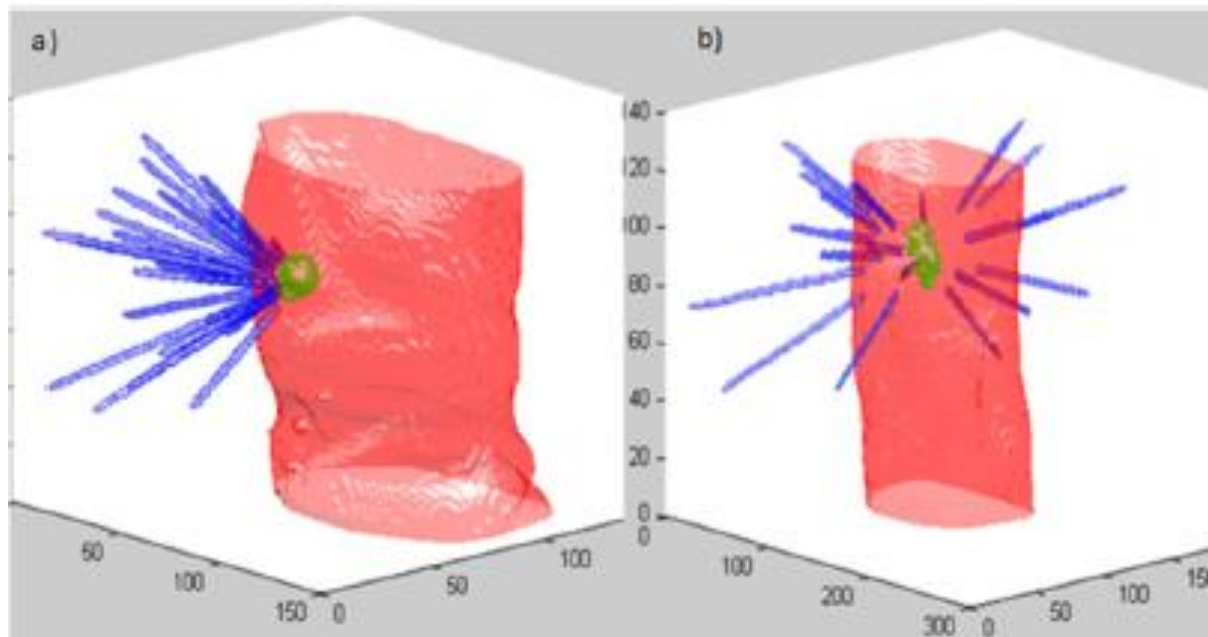

off-centered tumor

central tumor

Dong P., Sheng K et al. IJROB 2013

# Klinisches Szenario 1: Leber SBRT

4p Non-Coplanar Liver SBRT: A Novel Delivery Technique

n=10, Dosis 50-60Gy in 5#, VMAT-SBRT

14-22 non-coplanare Felder vs VMAT-Plan

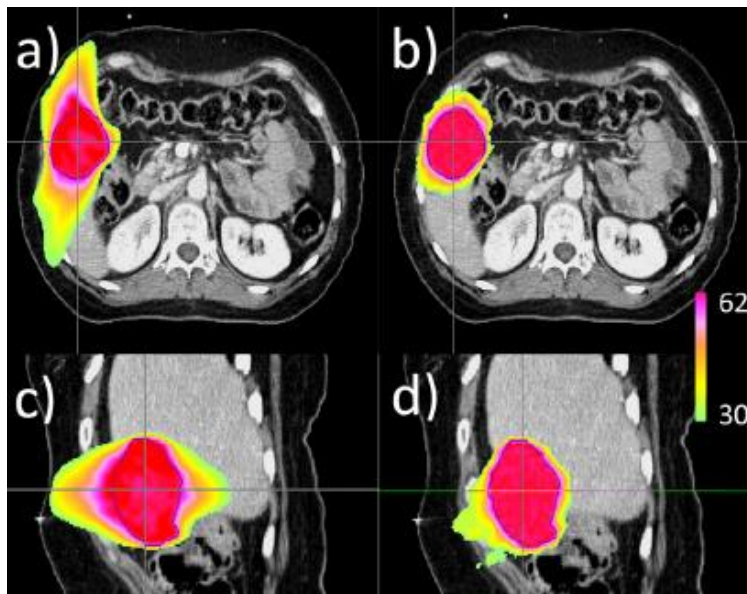

VMAT

4 $\pi$  planning

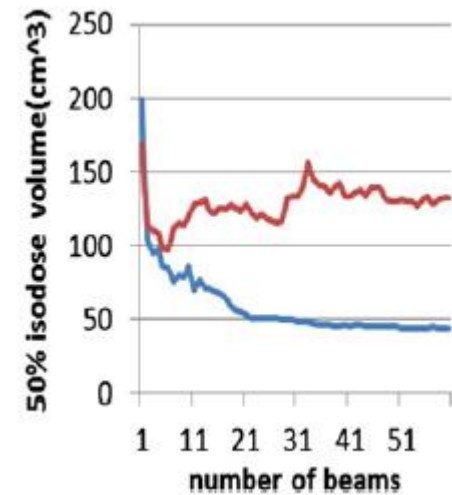
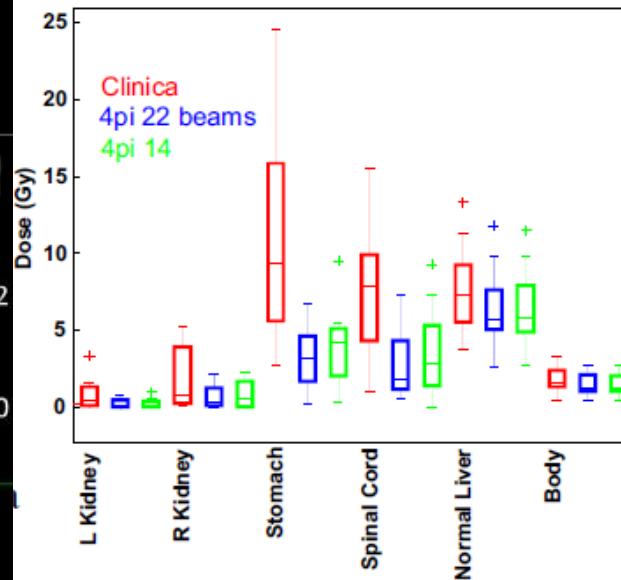

Dong P., Sheng K et al. IJROB 2013

# Klinisches Szenario 2a: Lungen SBRT zentral

4p Non-Coplanar Lung SBRT: A Novel Delivery Technique

n=12, Dosis 50-60Gy in 4-(5)#, VMAT-SBRT

20-30 non-coplanare Felder vs VMAT-Plan

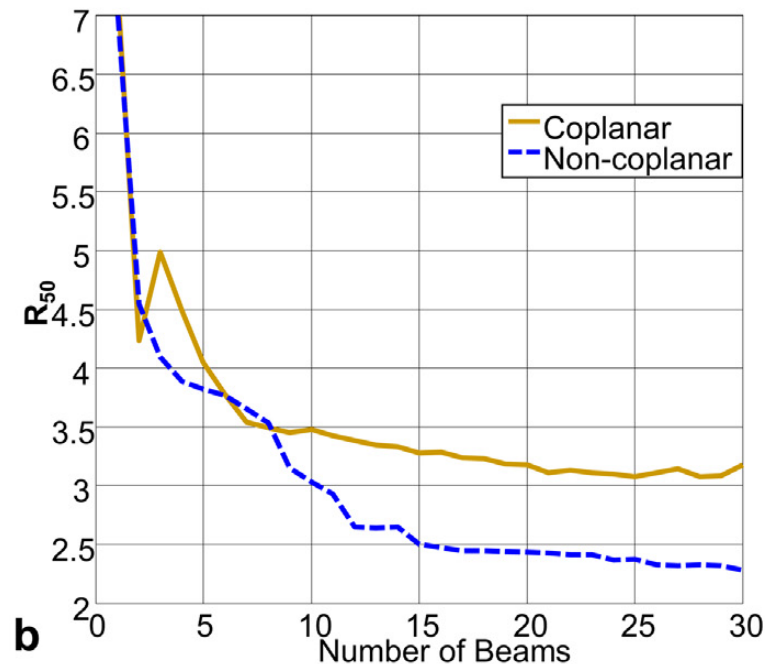
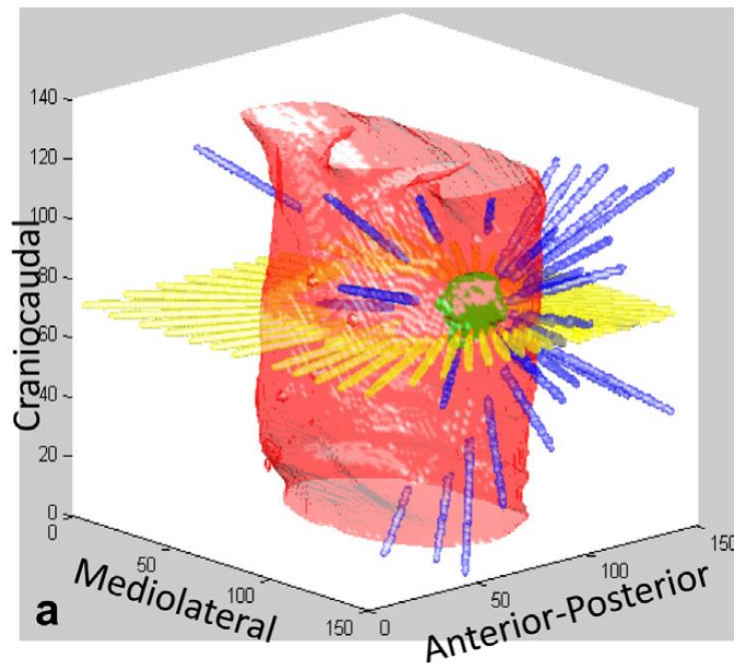

VMAT

4 $\pi$  planning

Dong P., Sheng K et al. IJROB 2013



# Klinisches Szenario 2a: Lungen SBRT zentral

4p Non-Coplanar Lung SBRT: A Novel Delivery Technique

n=12, Dosis 50-60Gy in 4-(5)#, VMAT-SBRT, 20-30 non-coplanare Felder vs VMAT-Plan

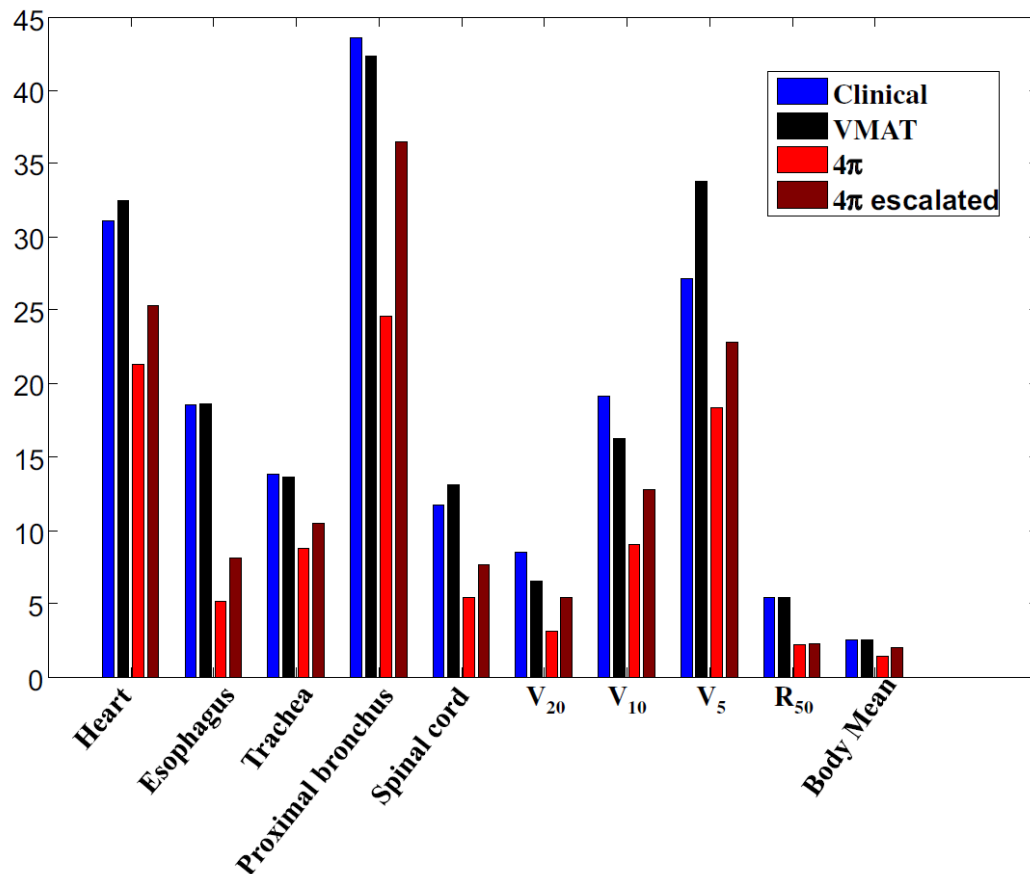

Dong P., Sheng K et al. IJROB 2013

# Klinisches Szenario 2a: Lungen SBRT zentral

4p Non-Coplanar Lung SBRT: A Novel Delivery Technique

n=12, Dosis 50-60Gy in 4-(5)#, VMAT-SBRT, 20-30 non-coplanare Felder vs VMAT-Plan

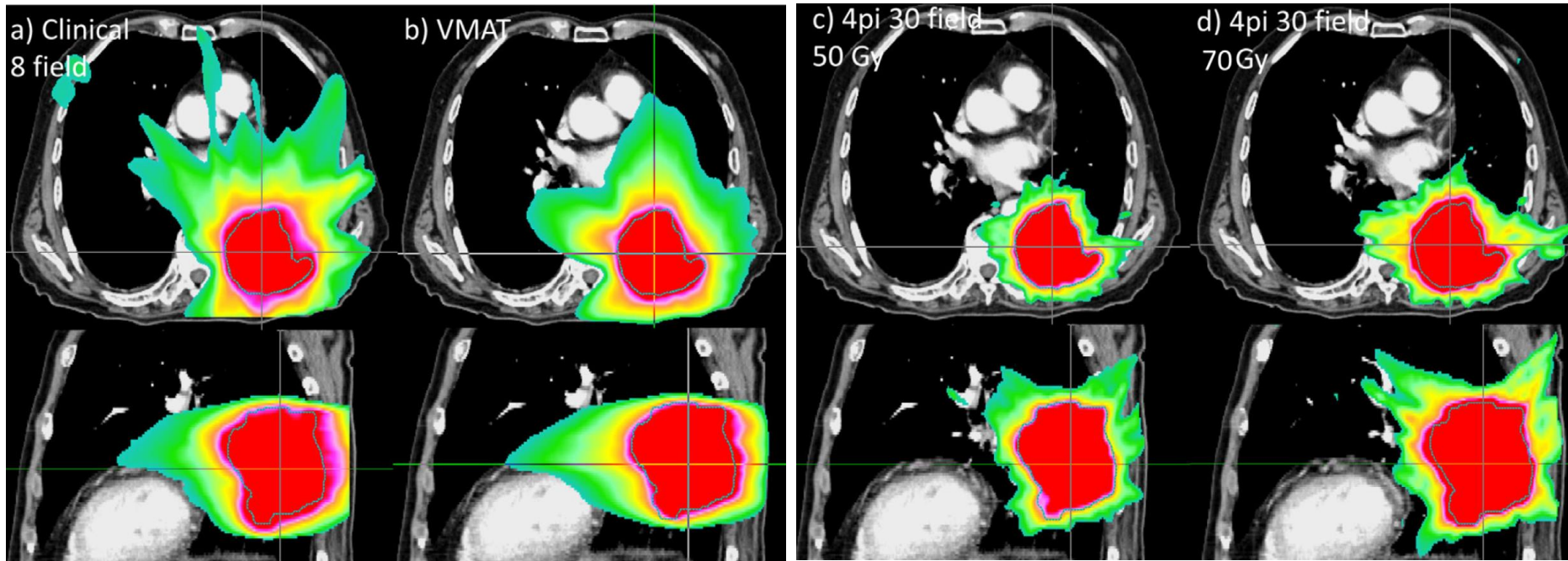

Dong P., Sheng K et al. IJROB 2013

# Klinisches Szenario 2a: Lungen SBRT zentral

## 4p Non-Coplanar Lung SBRT: A Novel Delivery Technique

n=12, Dosis 50-60Gy in 4-(5)#, VMAT-SBRT, 20-30 non-coplanare Felder vs VMAT-Plan

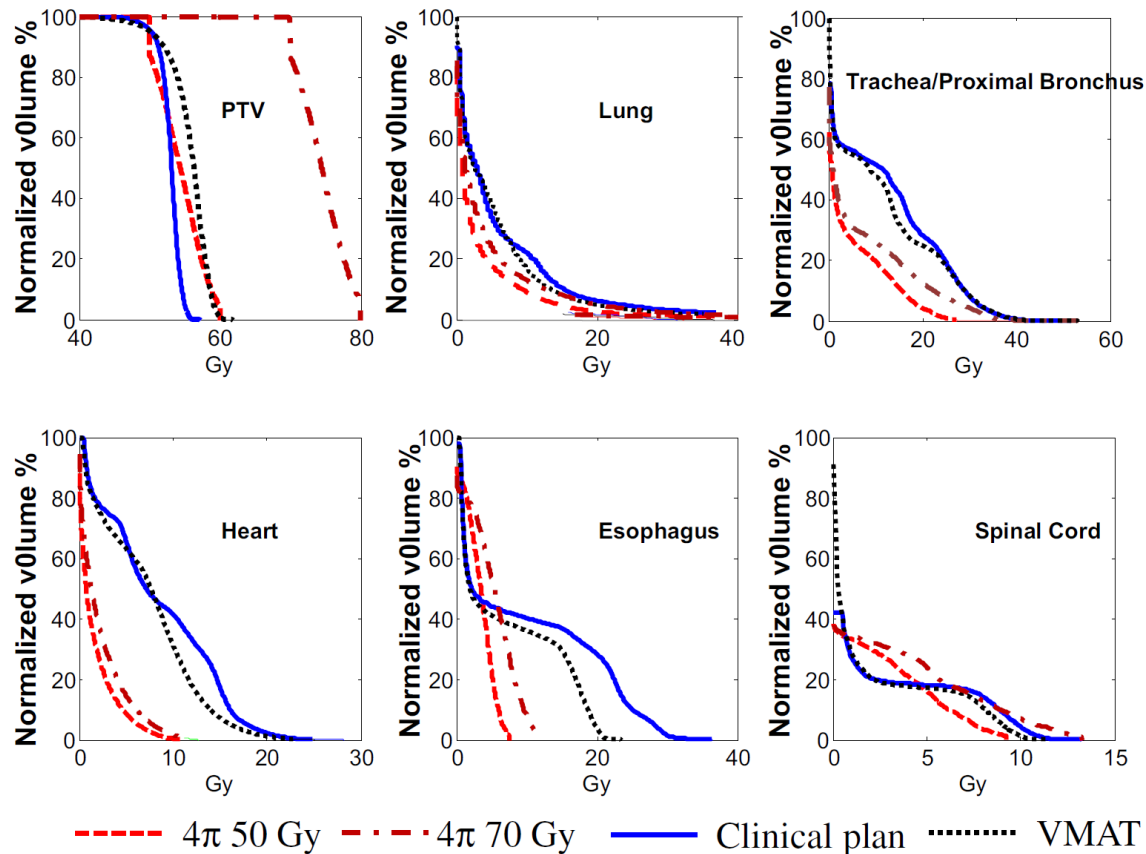

Dong P., Sheng K et al. IJROB 2013

# Klinisches Szenario 2b: Lungen SBRT

Non-Coplanar Lung SBRT: Tumore in Herznähe

n=20, Dosis 48-54Gy in 4#, VMAT-SBRT Coplanar 3 Arcs vs Non Coplanar 3 Arcs

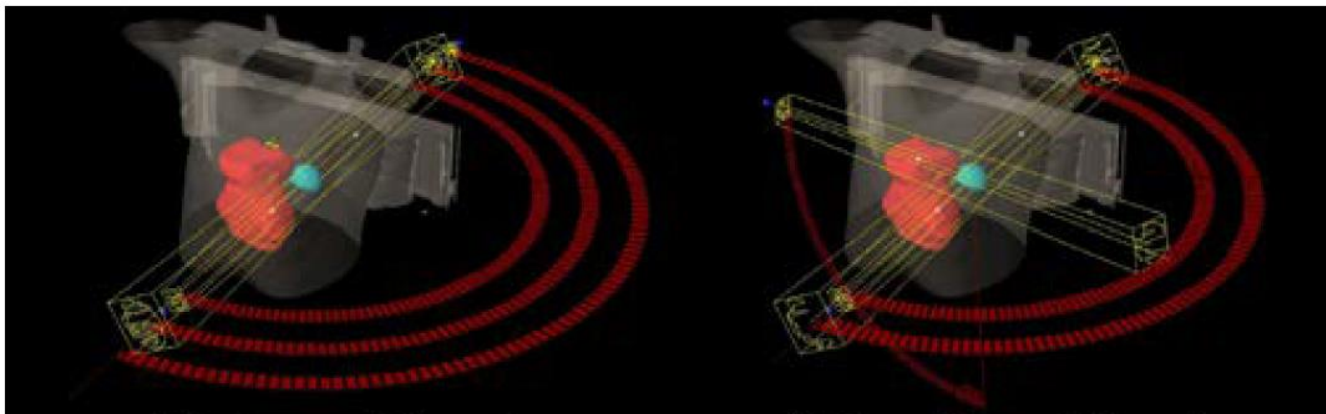

(a) Coplanar partial arc plan

(b) Non-coplanar partial arc plan

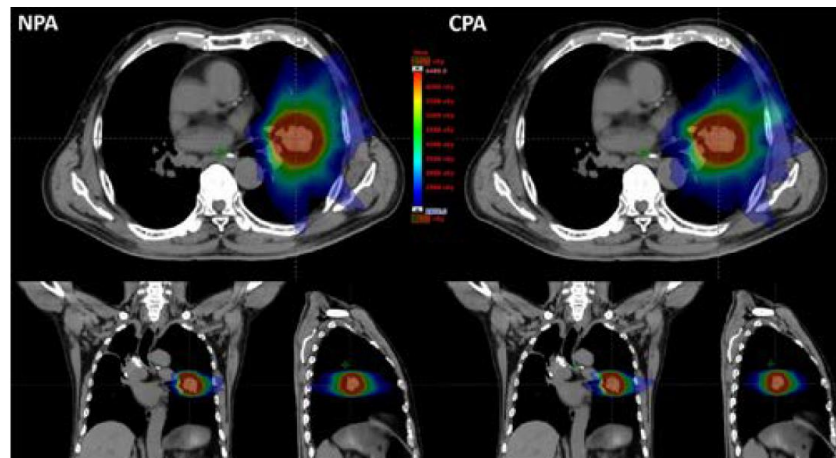

Kim S-T et al. Br J Radiol 2020

# Klinisches Szenario 2b: Lungen SBRT

Non-Coplanar Lung SBRT: Tumore in Herznähe

n=20, Dosis 48-54Gy in 4#, VMAT-SBRT Coplanar 3 Arcs vs Non Coplanar 3 Arcs

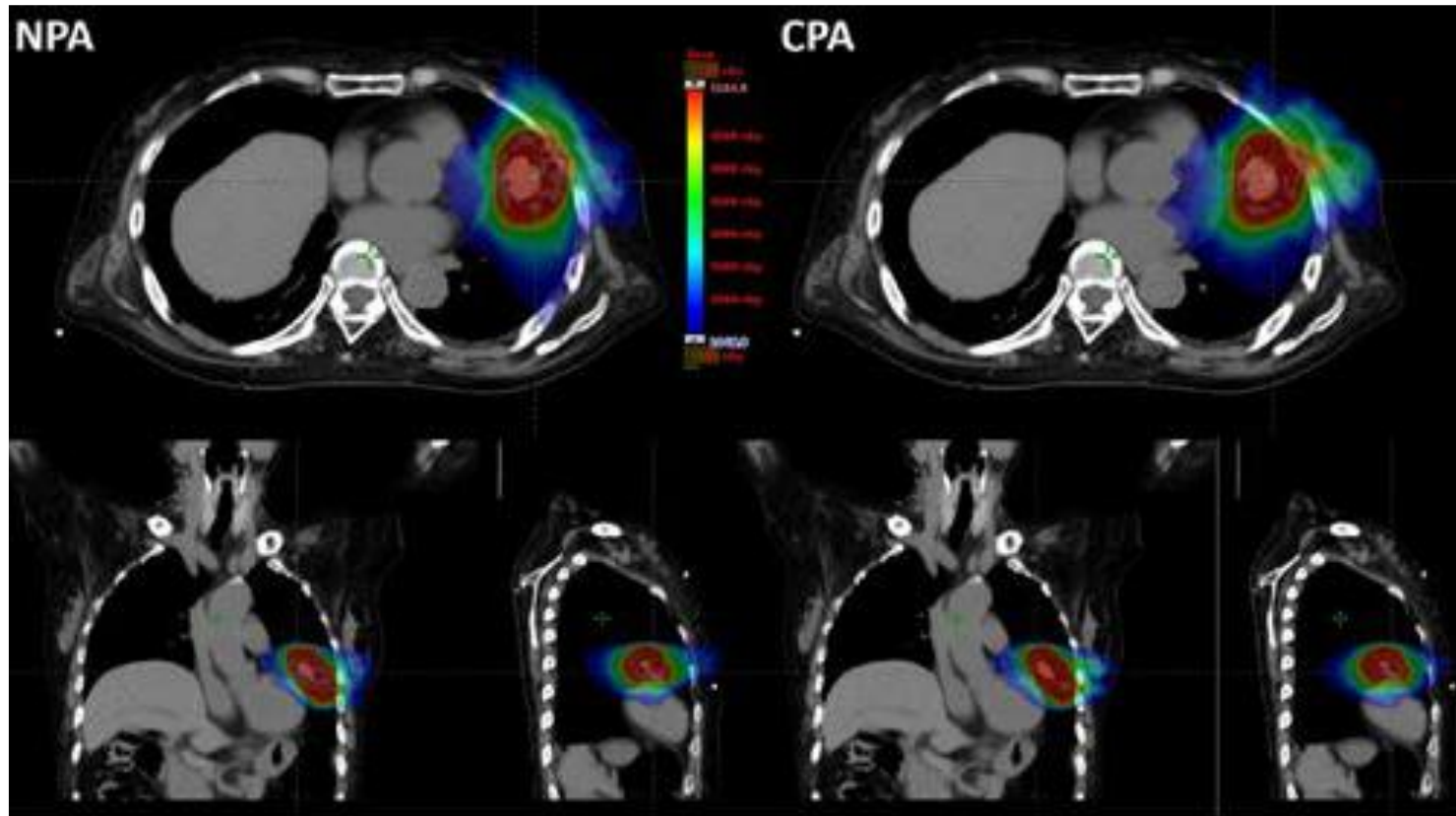

(c) NPA VMAT (patient No. 9)

(d) CPA VMAT (patient No. 9)

Kim S-T et al. Br J Radiol 2020

# Klinisches Szenario 2b: Lungen SBRT

Non-Coplanar Lung SBRT: Tumore in Herznähe

n=20, Dosis 48-54Gy in 4#, VMAT-SBRT Coplanar 3 Arcs vs Non Coplanar 3 Arcs

DV parameter	Coplanar VMAT	Non-coplanar VMAT	<i>p</i>
Maximum dose (Gy)	62.86 ± 2.66	62.78 ± 3.39	0.739
Mean dose (Gy)	60.28 ± 2.92	60.15 ± 3.42	0.524
Minimum dose (Gy)	51.03 ± 10.76	50.37 ± 11.18	0.043
D <sub>98%</sub> (Gy)	57.31 ± 5.18	57.34 ± 5.18	0.765
D <sub>95%</sub> (Gy)	58.50 ± 3.73	58.50 ± 3.73	-
D <sub>5%</sub> (Gy)	61.47 ± 2.75	61.31 ± 3.35	0.480
D <sub>2%</sub> (Gy)	61.72 ± 2.75	61.55 ± 3.35	0.486
Homogeneity index	0.075 ± 0.052	0.072 ± 0.046	0.518
Conformity index	1.008 ± 0.032	1.001 ± 0.029	0.226

DV parameter, dose-volumetric parameter; D<sub>n%</sub>, dose received by at least *n*% volume of the planning target volume.; VMAT, volumetric modulated arc therapy.

# Klinisches Szenario 2b: Lungen SBRT

Non-Coplanar Lung SBRT: Tumore in Herznähe

n=20, Dosis 48-54Gy in 4#, VMAT-SBRT Coplanar 3 Arcs vs Non Coplanar 3 Arcs

DV parameter	Coplanar VMAT	Non-coplanar VMAT	<i>p</i>
<b>Heart</b>			
Maximum dose (Gy)	32.40 ± 14.33	25.72 ± 12.26	<0.001
Mean dose (Gy)	2.85 ± 1.93	2.34 ± 1.72	<0.001
D <sub>0.1cc</sub> (Gy)	29.42 ± 13.37	21.71 ± 9.20	<0.001
D <sub>2%</sub> (Gy)	15.10 ± 6.75	12.53 ± 6.49	<0.001
V <sub>34Gy</sub> (cm <sup>3</sup> )	1.13 ± 2.23	0.00 ± 0.01	0.041
V <sub>28Gy</sub> (cm <sup>3</sup> )	2.51 ± 4.11	1.72 ± 3.30	0.004
V <sub>20Gy</sub> (cm <sup>3</sup> )	31.04 ± 10.59	24.32 ± 8.04	<0.001
V <sub>10Gy</sub> (cm <sup>3</sup> )	143.01 ± 43.18	110.68 ± 36.19	<0.001
<b>Esophagus</b>			
Mean dose (Gy)	1.57 ± 0.81	1.22 ± 0.58	<0.001
V <sub>30Gy</sub> (cm <sup>3</sup> )	0.00 ± 0.00	0.00 ± 0.00	-
V <sub>18.8 Gy</sub> (cm <sup>3</sup> )	0.01 ± 0.02	0.00 ± 0.00	0.330
<b>Trachea and bronchi</b>			
D <sub>2%</sub> (Gy)	12.41 ± 8.46	10.76 ± 7.54	0.006
D <sub>0.1cc</sub> (Gy)	15.47 ± 10.64	13.99 ± 10.67	0.023
V <sub>34.8 Gy</sub> (cm <sup>3</sup> )	0.02 ± 0.06	0.02 ± 0.09	0.623
V <sub>15.6 Gy</sub> (cm <sup>3</sup> )	1.14 ± 2.45	0.75 ± 1.77	0.073

Kim S-T et al. Br J Radiol 2020

# Klinisches Szenario 2c: Lungen SBRT

Non-Coplanar Lung SBRT: Tumore in Herznähe

n=46, Dosis 60Gy in 5#, VMAT Coplanar vs Non Coplanar 5Teilarcs

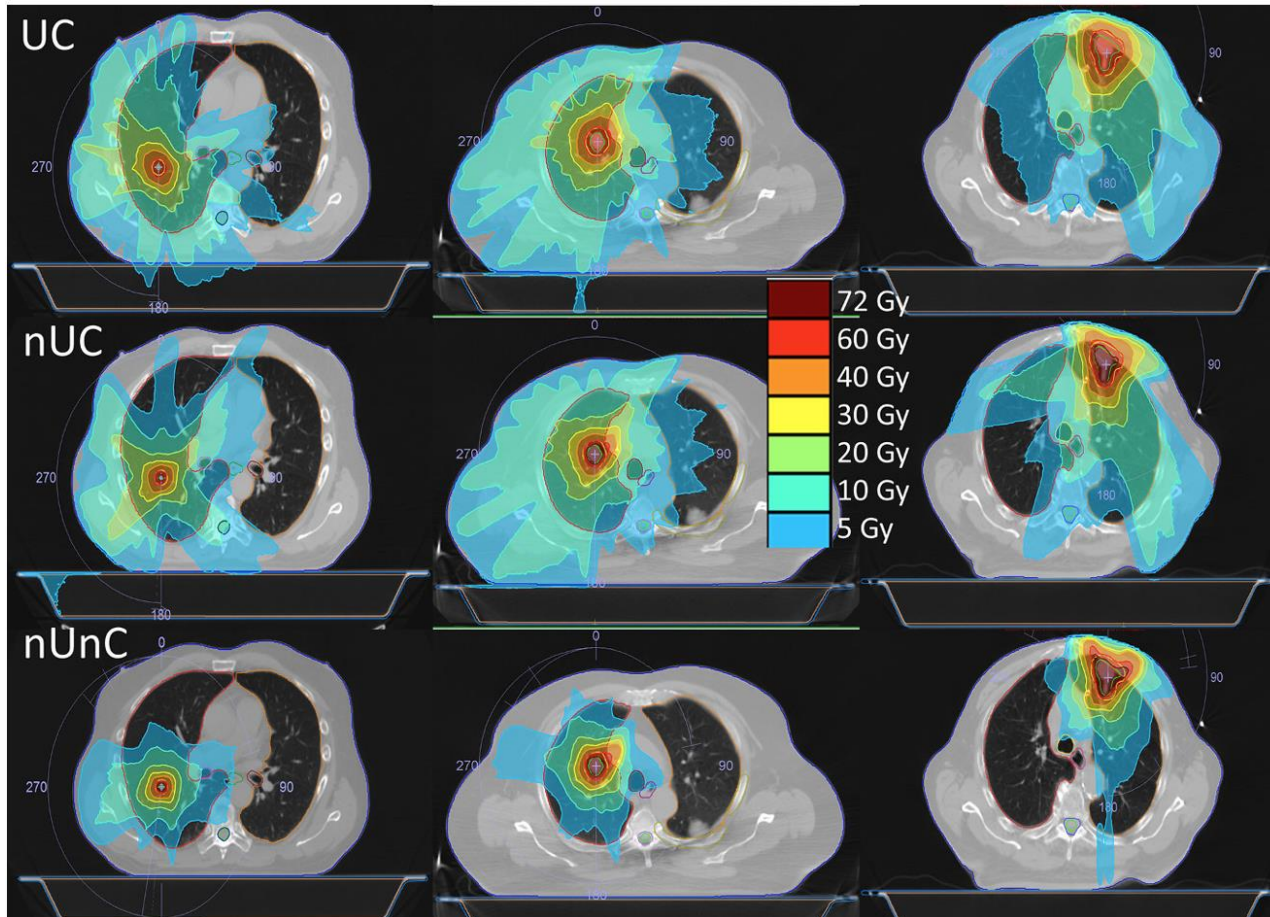

Fleckenstein J et al. STO 2018



# Klinisches Szenario 2c: Lungen SBRT

Non-Coplanar Lung SBRT: Tumore in Herznähe

n=46, Dosis 48-54Gy in 4#, VMAT-SBRT Coplanar vs Non Coplanar 5 Teilarcs

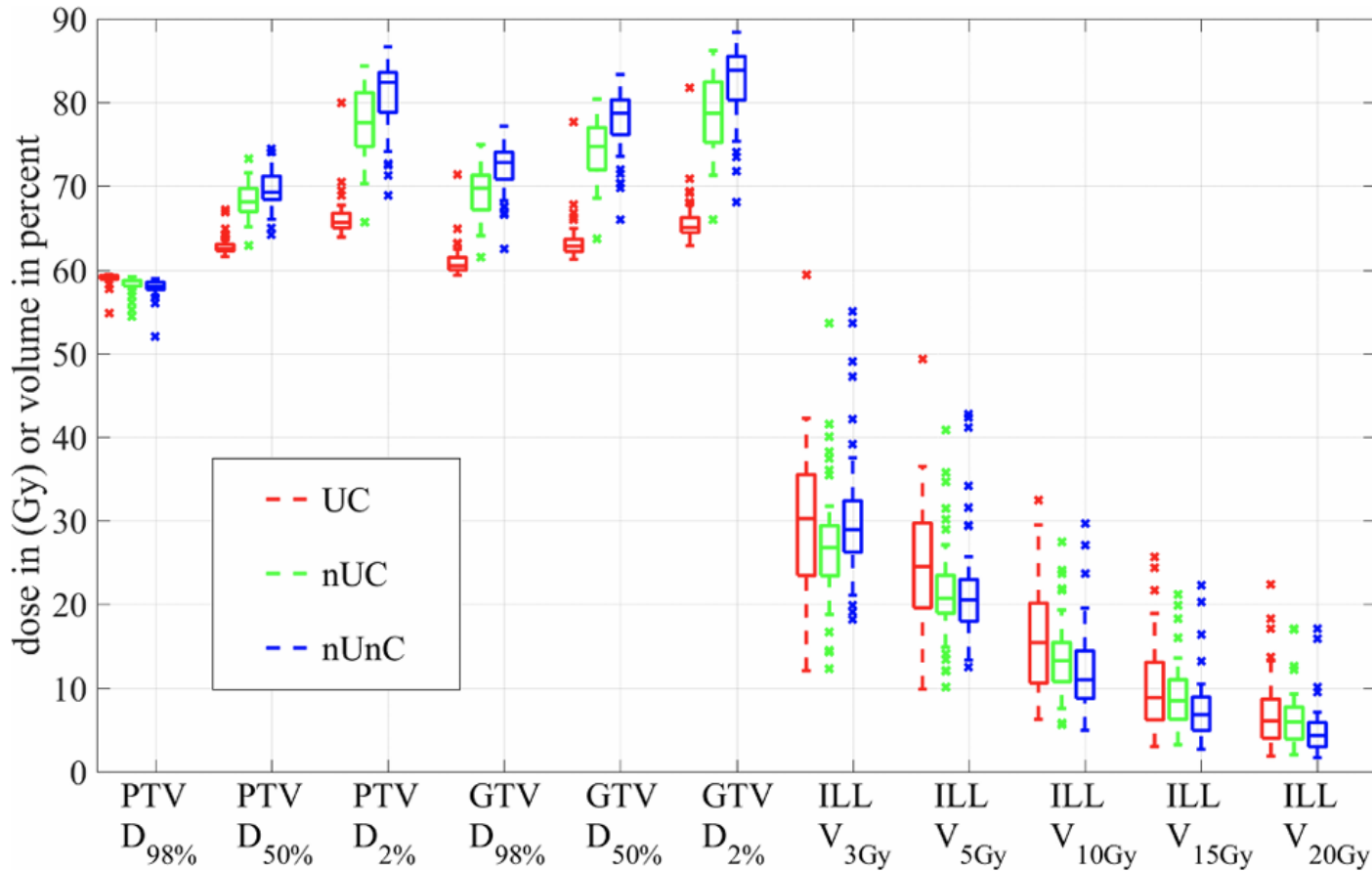

Fleckenstein J et al. STO 2018

# Klinisches Szenario 3: Prostatabestrahlung

Planungsstudie: Protonen, VMAT, non-coplanare RT

n=10, Dosis 79,2Gy in 40#, 2 Feder IMPT, VMAT (2arcs) und 30 non-coplanare Felder

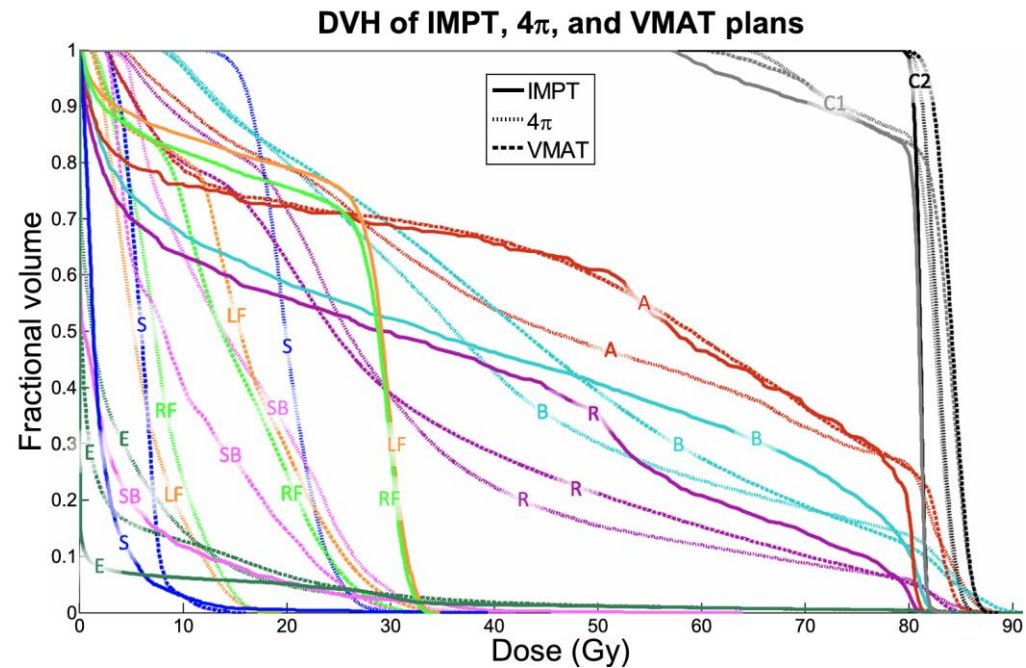
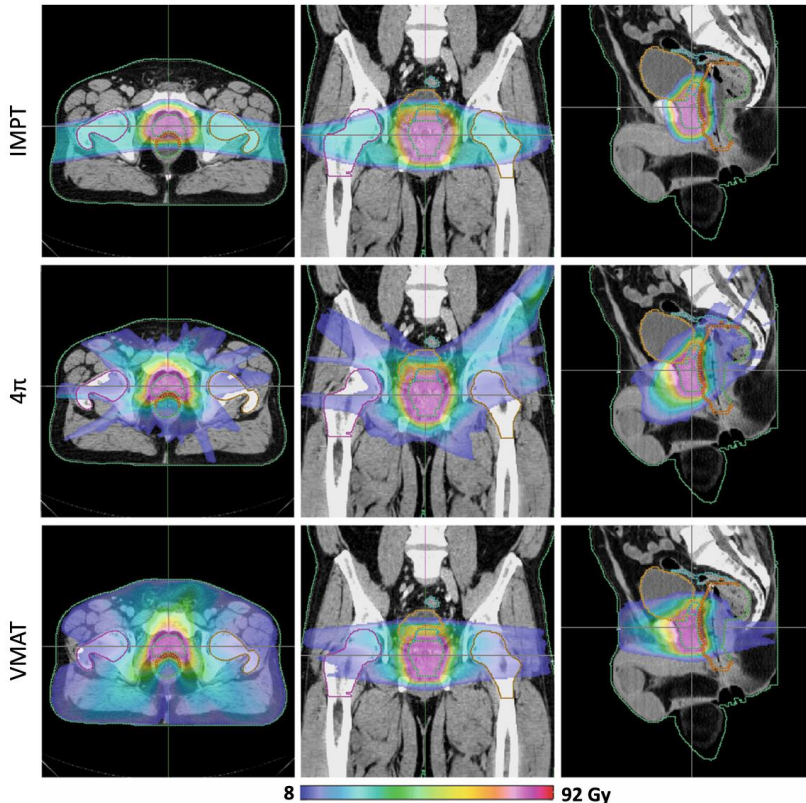

Tran A., Sheng K Radiat Oncol 2017

# Klinisches Szenario 3: Prostatabestrahlung

Planungsstudie: Protonen, VMAT, non-coplanare RT

n=10, Dosis 79,2Gy in 40#, 2 Feder IMPT, VMAT (2arcs) und 30 non-coplanare Felder

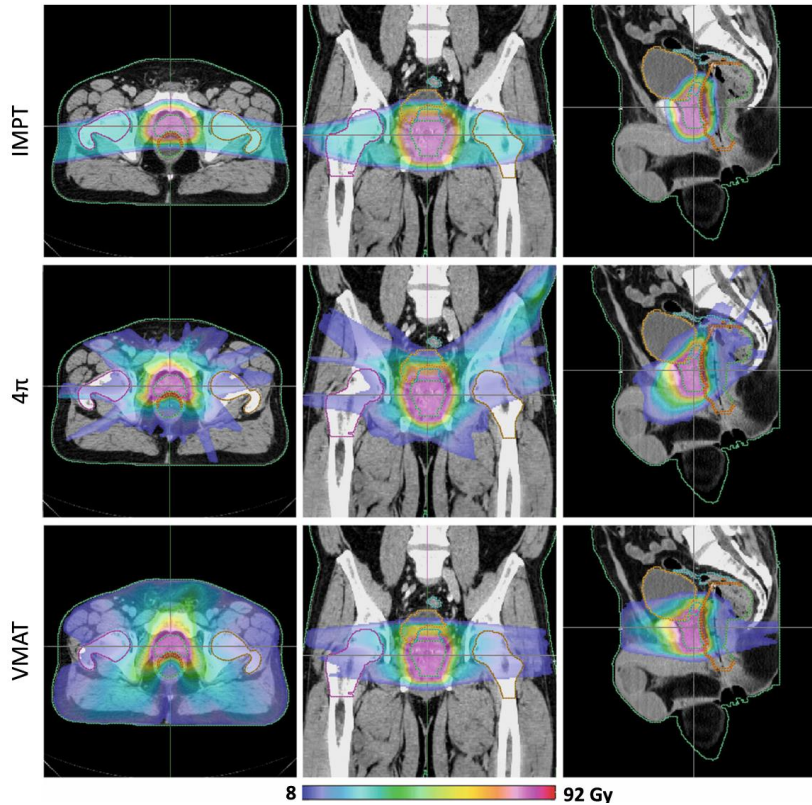

- IMPT bessere CTV Homogenität und Max Dosis bei OAR's
- 4π bessere mittlere Rektum und Blasendosis.
- 4π im Vergl. VMAT dosimetrisch überlegen.

Tran A., Sheng K Radiat Oncol 2017

# Klinisches Szenario 4: Spinale SBRT

n = 11 Knochenmetastasen, SIB Technik 35-40Gy (PTVHD) und 20-25 Gy (PTVED)

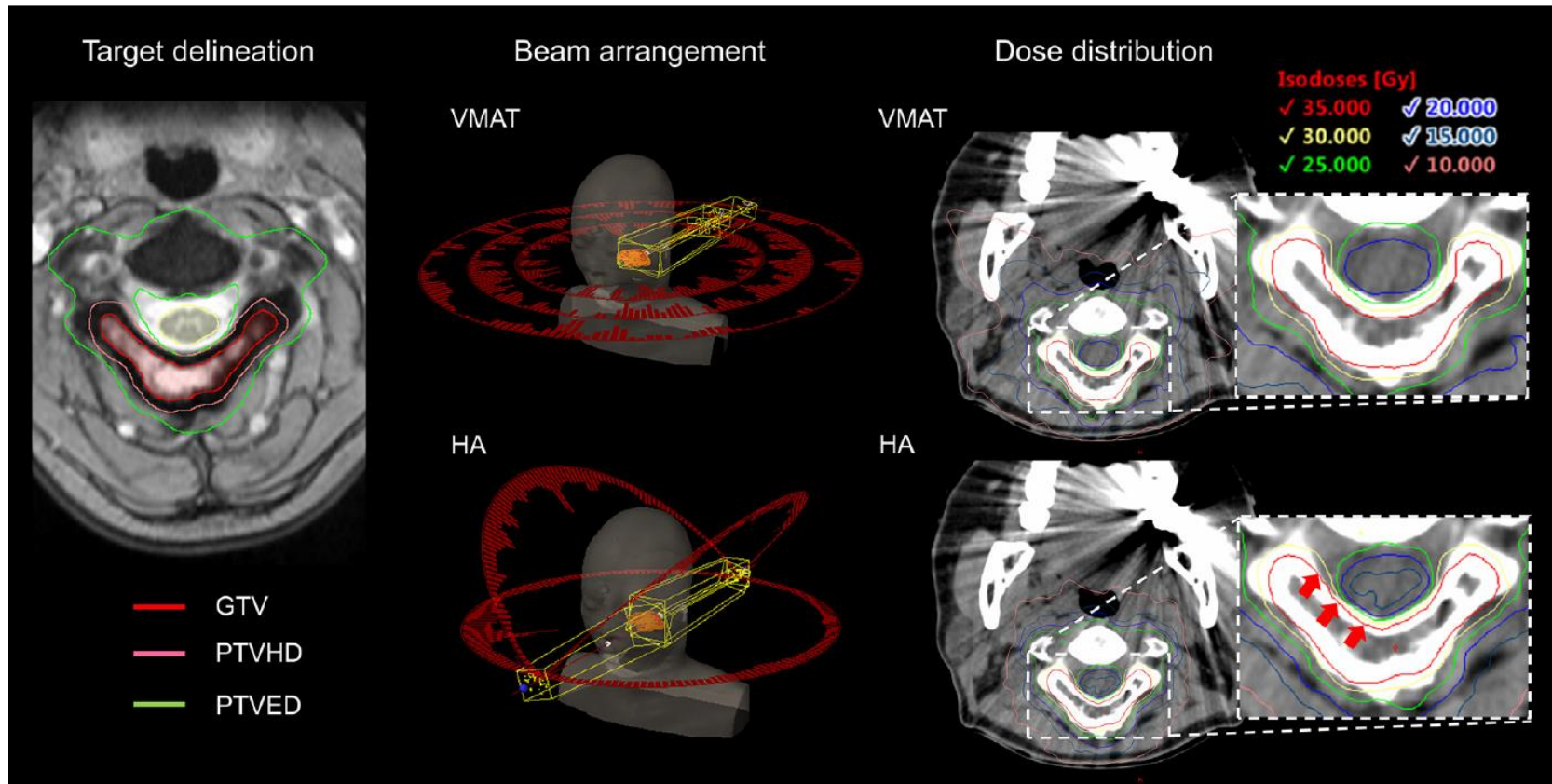

Ohira S. et al. Med Dosim. 2023

# Klinisches Szenario 4: Spinale SBRT

n = 11 Knochenmetastasen, SIB Technik 35-40Gy (PTVHD) und 20-25 Gy (PTVED)

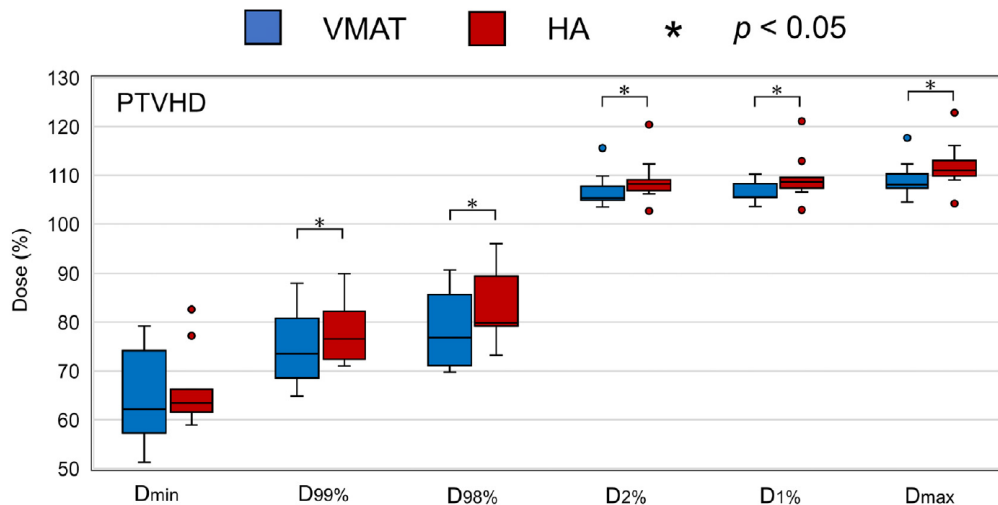

Dosimetric parameters for OARs

Structure	Dosimetric parameter	VMAT		HA		p-value
		Mean	SD	Mean	SD	
Spinal cord (n = 11)	Dmax (Gy)	24.3	2.7	24.5	2.6	n.s.
Esophagus (n = 6)	Dmax (Gy)			24.1	4.2	n.s.
Brachial plexus (n = 6)	Dmax (Gy)			30.7	2.5	n.s.
Larynx (n = 11)	Dmax (Gy)			3.0	1.8	n.s.
Pharyngeal constrictor (n = 11)	Dmean (Gy)	9.1	6.4	8.1	5.3	n.s.
Thyroid (n = 11)	Dmean (Gy)	3.3	4.0	3.3	3.6	n.s.
Parotid grand (left) (n = 11)	Dmean (Gy)	1.2	2.0	1.8	1.2	n.s.
Parotid grand (right) (n = 11)	Dmean (Gy)	1.4	2.4	1.6	0.8	n.s.
Submandibular gland (left) (n = 11)	Dmean (Gy)	1.6	2.1	2.3	1.0	n.s.
Submandibular gland (right) (n = 11)	Dmean (Gy)	1.9	2.5	2.4	1.0	n.s.
Entire body (n = 11)	V <sub>20Gy</sub> (cm <sup>3</sup> )	87.0	53.3	74.4	47.7	0.004
	V <sub>15Gy</sub> (cm <sup>3</sup> )	150.9	88.3	113.1	73.1	0.003
	V <sub>10Gy</sub> (cm <sup>3</sup> )	288.3	160.0	199.6	129.6	0.003

Ohira S. et al. Med Dosim. 2023

# Klinisches Szenario 5: Head and Neck SBRT

n = 27 ( 29 Rezidivtumore) Kopf-Hals, SIB Technik 35-44 in 5#Gy,

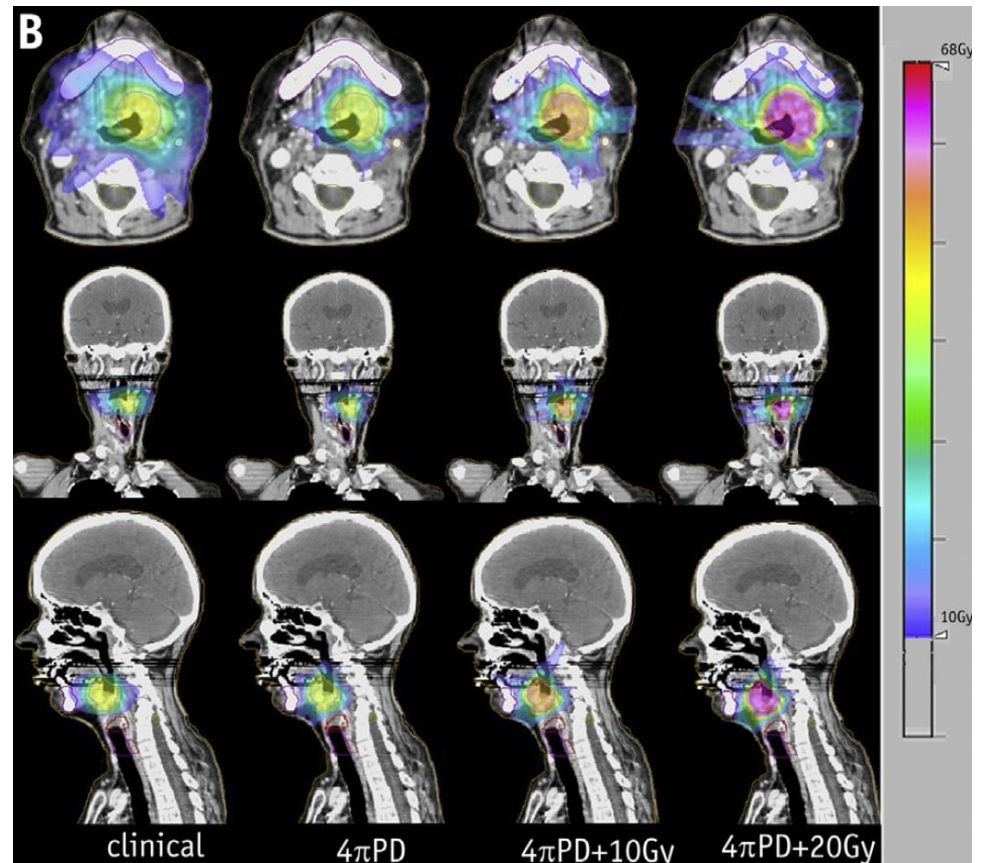
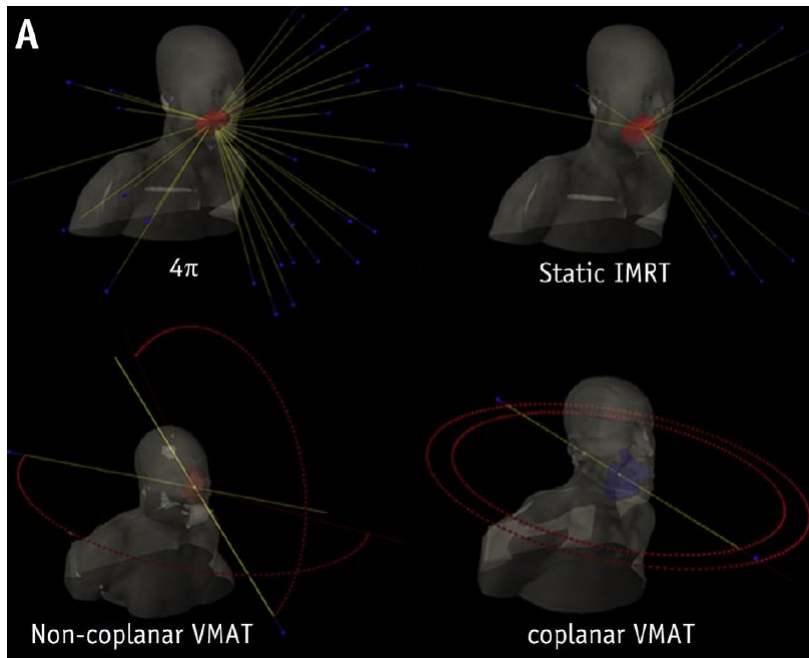

Rwigema JC et al. IJROB 2014

# Klinisches Szenario 5: Head and Neck SBRT

n = 27 ( 29 Rezidivtumore) Kopf-Hals, SIB Technik 35-44 in 5#Gy,

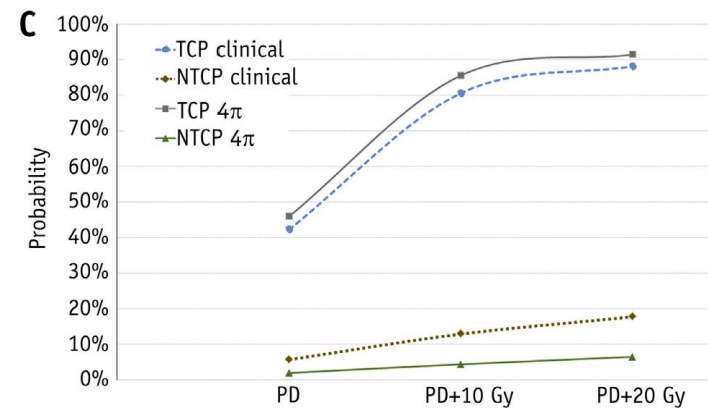
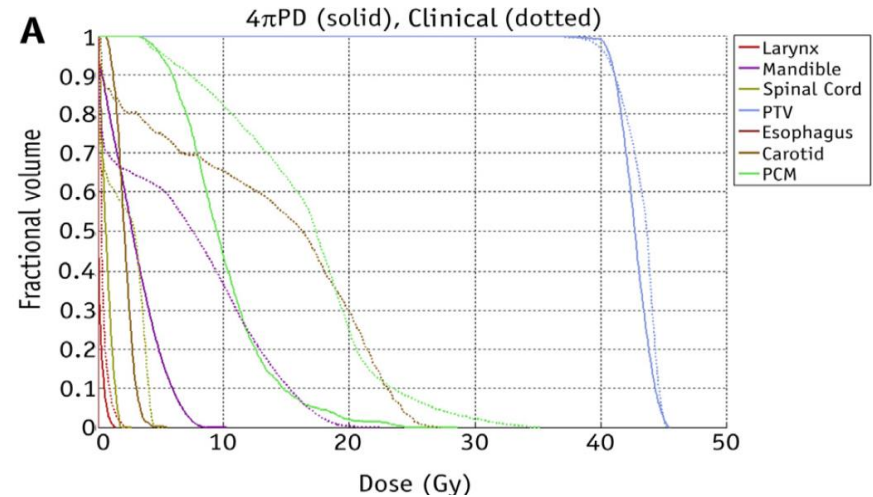
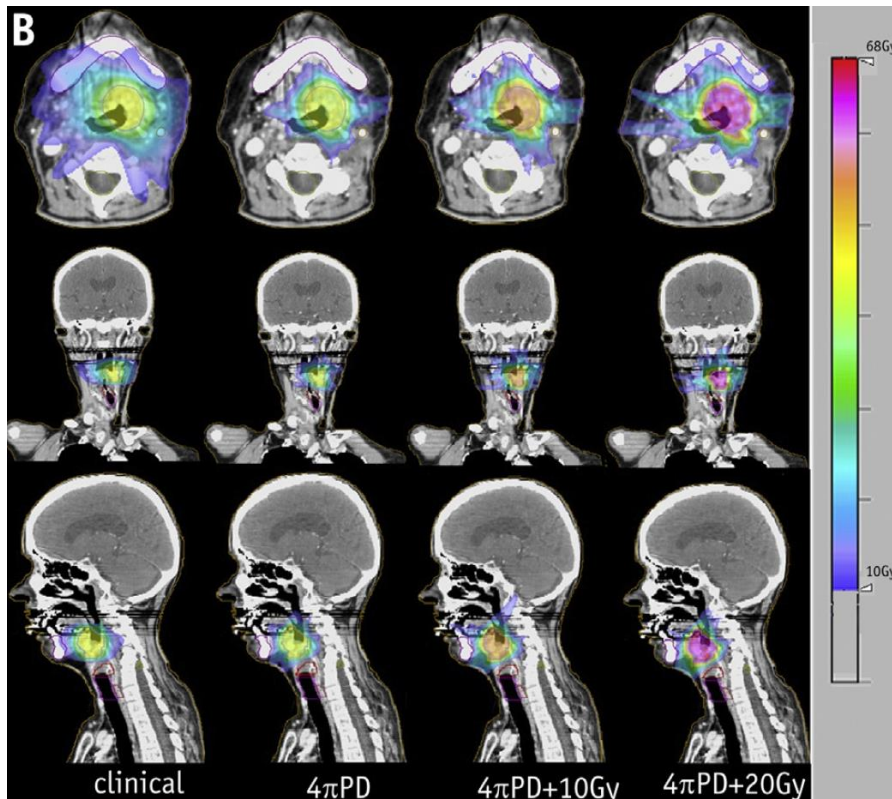

Rwigema JC et al. IJROB 2014

# Extrakranielle non-coplanare Bestrahlung – Zusammenfassung –

Besondere Bedeutung bei stereotaktischen Hochpräzisionstherapien, extremer Hypofraktionierung, Schonung von OAR's, Dosisescalation

## Con's

- Komplexe Planung
- Höheres Risiko für Einstellungsfehler
- Erhöhtes Kollisionsrisiko
- Behandlungszeit
- Nur geringe Planverbesserung

## Pro's

- steilerer Dosisabfall
- bessere Konformität
- bessere Schonung OAR's
- weniger Nebenwirkungen
- Dosisescalation
- bessere lokale Kontrolle

Realität?  
Praxis?



# Extrakranielle non-coplanare Bestrahlung – Muss oder Spielerei –

Extrakranielle non-coplanare Bestrahlung

Nutzung in der Routine

in Ausnahmefällen vorstellbar

eher Spielerei



# Gemeinsam fürs

